

3M

Compact Earset Intercom System

Model C1025

Replacement Parts and Service

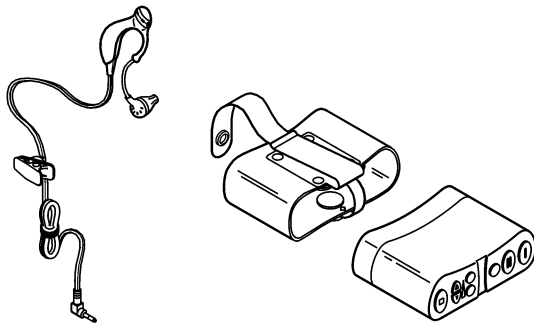

Compact Earset and Transceiver Pack

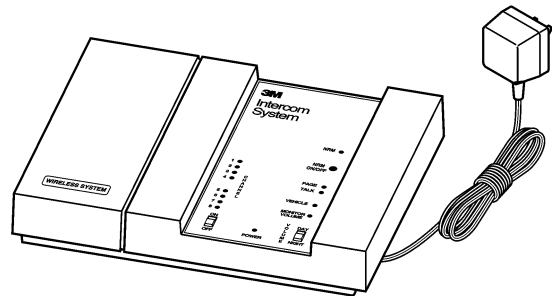

Base Station

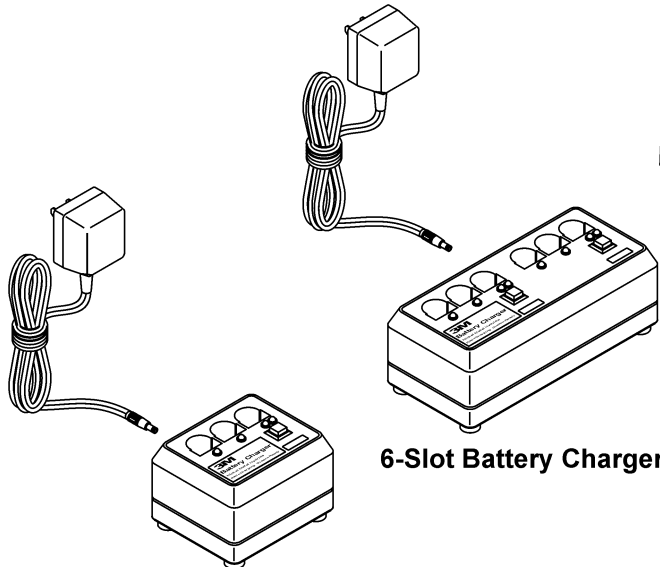

6-Slot Battery Charger

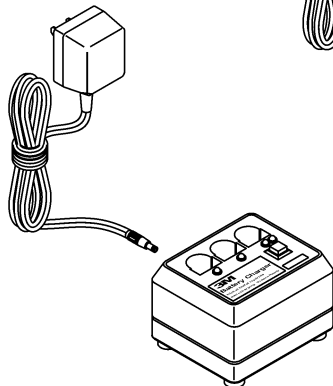

3-Slot Battery Charger

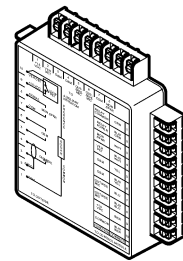

Interconnect Module

(this page intentionally left blank)

Compact Earset Assembly

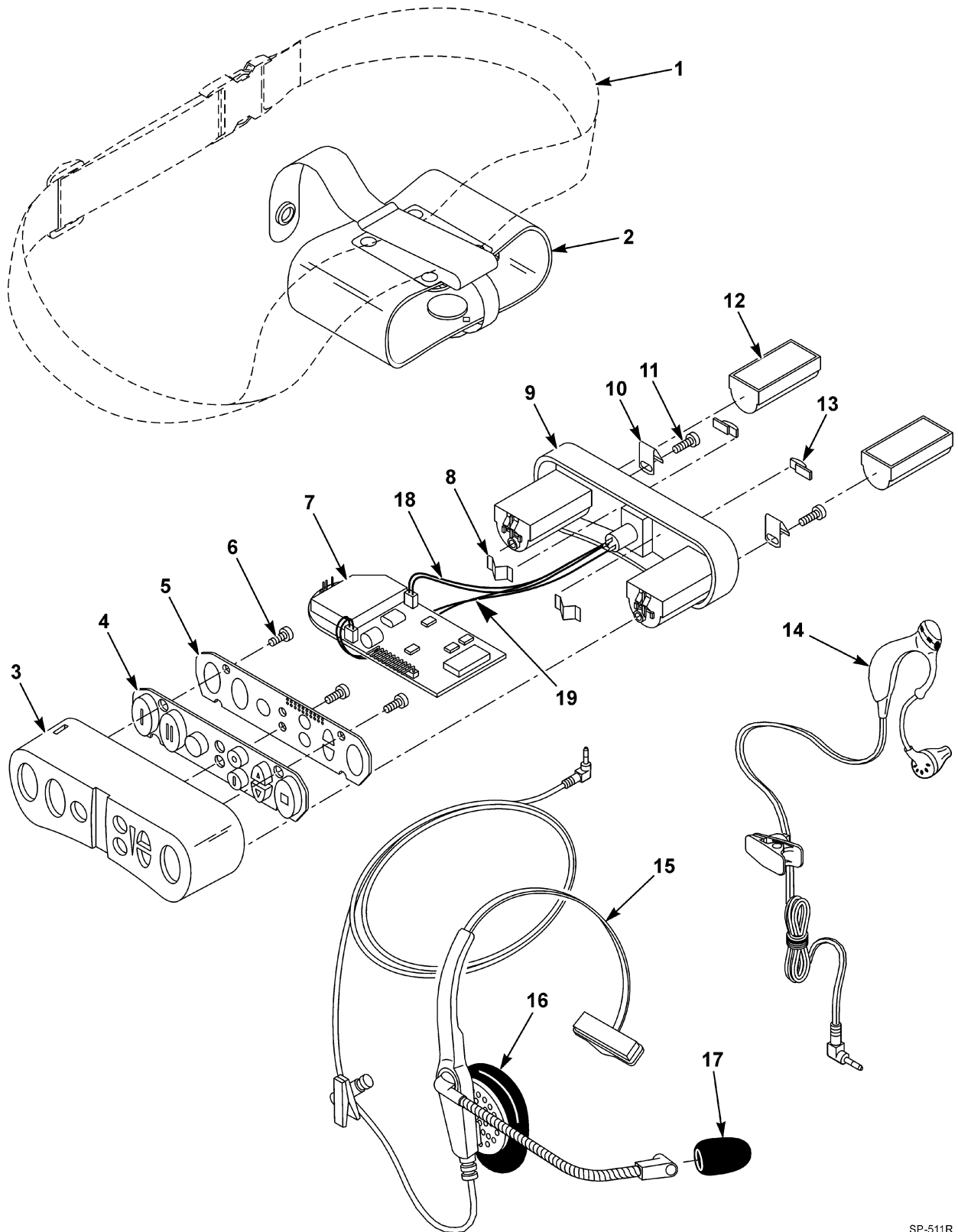

SP-511R

Item No.	Part Number	Description	Qty.
1	78-8095-0528-8	BELT (Optional)	1
2	78-8095-0531-2	POUCH	1
3	78-8095-0535-3	CASE, Top with Logo, Black	1
4	78-8095-0515-5	KEYPAD	1
5	78-8095-0518-9	KEYPAD PWA	1
6	26-1014-7489-3	SCREW, Pan, Plastite, 6x1/4"	3
7	78-8095-0517-1	MAIN PWA	1
8	78-8095-0556-9	SPRING, Battery Release Button	2
9	78-8095-0536-1	CASE, Base Assembly, Black (includes Battery Contacts and Cable)	1
10	78-8095-0517-1	SPRING, Battery Ejector	2
11	26-1014-7488-5	SCREW, Pan, Plastite, 6x16x3/8"	2
12	78-6911-4491-5	BATTERY ASSEMBLY	2
13	78-8095-0551-0	BUTTON, Battery Release	2
14	78-8110-9573-2	COMPACT EARSET (Package of 2)	1
15	78-8095-0381-2	HEADSET, Type III C1025 with 2.5mm Plug, Flex Boom	1
16	78-6911-4829-6	EAR PAD, Type III (Package of 10), Flex Boom	1
17	78-6911-4745-4	WINDSCREEN, Microphone (Package of 10)	1
18	78-8095-0454-7	HARNESS, Internal Microphone C1025/C960SL (2 Wires)	1
19	78-8095-0453-9	HARNESS, Internal Speaker C1025/C960SL (1 Wire)	1
20	78-6911-4710-8	C860/1025 SWITCH PROTECTOR (Not Shown)	1